

06

Fresas para máquinas portáteis
Fresas para máquinas portáteis



araújo&silva
ferramentas de corte

JÁ MEDIU A SUA PRODUTIVIDADE?



A Araujo&Silva, Lda. desenvolve ferramentas especiais, proporcionando aos seus clientes as soluções mais rentáveis.

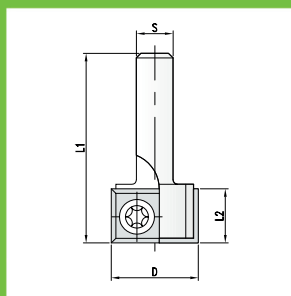
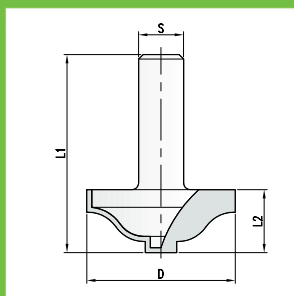
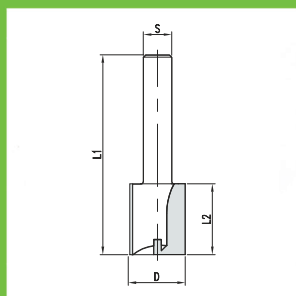

araújo&silva
ferramentas de corte

ESPECIALISTAS EM FERRAMENTA DE CORTE

www.araujosilva.pt



HW · MAN

D	L2	L1	S	Z	Ref.
6	14	48	6	2	3064.006.014.06
	14	55	8	2	3064.006.014.08
8	20	48	6	2	3064.008.020.06
	20	55	8	2	3064.008.020.08
10	20	48	6	2	3064.010.020.06
	20	60	8	2	3064.010.020.08
	30	90	8	2	3064.010.030.08
12	20	48	6	2	3064.012.020.06
	20	90	8	2	3064.012.020.08
	30	90	8	2	3064.012.030.08
14	20	48	6	2	3064.014.020.06
	20	60	8	2	3064.014.020.08
	30	90	8	2	3064.014.030.08
16	25	53	6	2	3064.016.025.06
	20	70	8	2	3064.016.020.08
18	25	53	6	2	3064.018.025.06
	20	70	8	2	3064.018.020.08
20	25	53	6	2	3064.020.025.06
	20	70	8	2	3064.020.020.08
22	16	70	8	2	3064.022.016.08
24	16	70	8	2	3064.024.016.08
25	16	70	8	2	3064.025.016.08

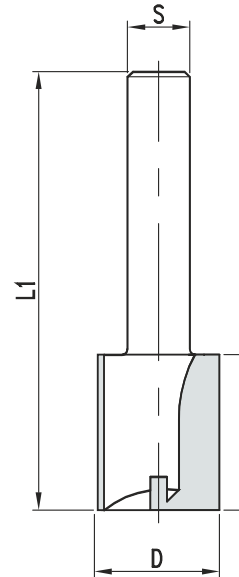

Fresa para Ranhurar, HW Integral **3066**
Fresa para ranurar, HW integral

HW · MAN

D	L2	L1	S	Z	Ref.
3	8	48	8	2	3066.003.008.08
	8	48	10	2	3066.003.008.10
4	10	51	8	2	3066.004.010.08
	10	51	10	2	3066.004.010.10
5	12	51	8	2	3066.005.012.08
	12	51	10	2	3066.005.012.10
6	12	52	8	2	3066.006.012.08
	12	52	10	2	3066.006.012.10

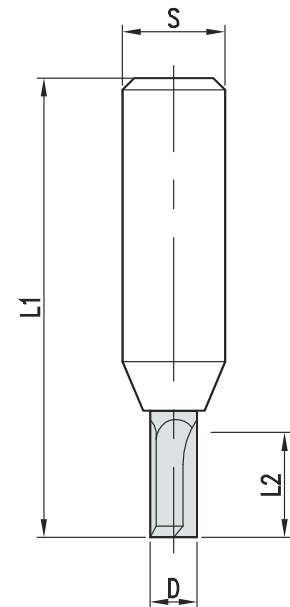



3520 Porta-lâminas para ranhurar

Porta-cuchillas para ranurar con cuchillas reversibles

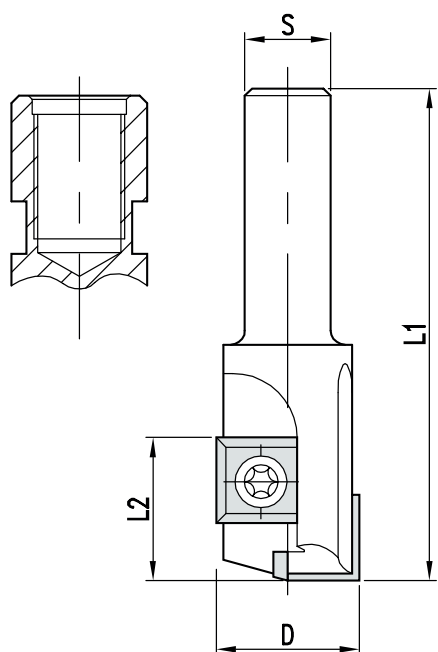

HW · MAN

D	L2	L1	S	Z	Ref.
16	20	70	8	2	3520.016.020.08
	20	70	10	2	3520.016.020.10
18	20	70	8	2	3520.018.020.08
	20	70	10	2	3520.018.020.10
20	20	70	8	2	3520.020.020.08
	20	70	10	2	3520.020.020.10
22	20	70	8	2	3520.022.020.08
	20	70	10	2	3520.022.020.10

ACESSÓRIOS - Peças de recambio

	Dim.	Ref.
Lâmina	12x12x1,5	5003.01.1
Parafuso (Torx)	M4x6	5109.006
Chave Torx	T15SW4 (M8)	5302.202

3521 Porta-lâminas para ranhurar

Porta-cuchillas para ranurar con cuchillas reversibles

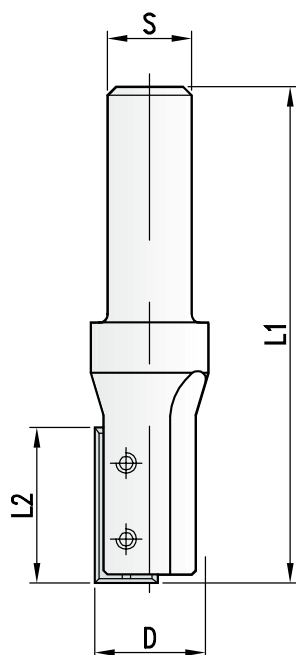

HC · MAN

D	L2	L1	S	Z	Ref.
18	20	63	8*	1	3521.008.020.08
10	20	63	8*	1	3521.010.020.08
12	20	63	8*	1	3521.012.020.08
14	20	59	8*	1	3521.014.020.08
15	20	59	8*	1	3521.015.020.08

* S=10/12, ver página (ref.3640)

ACESSÓRIOS - Peças de recambio

	Dim.	Ref.	
Lâmina**	∅8/12	20x5,5x1,1	5009.501
	∅14/15	20x10x1,5	5009.502
Perno	M2,5x2,5		5106.001
	M4x4		5106.002
Chave	SW1,3		5302.003
	SW2		5302.005

** Metal Duro revestido



HW · MAN

D	L2	L1	S	Z	Ref.
19	12	45	6	2	3500.019.012.06
	12	45	8	2	3500.019.012.08

ACESSÓRIOS - Piezas de recambio

	Dim.	Ref.
Lâmina	12x12x1,5	5003.01.1
Parafuso (Torx)	M4x6	5109.006
Chave Torx	T15	5302.202

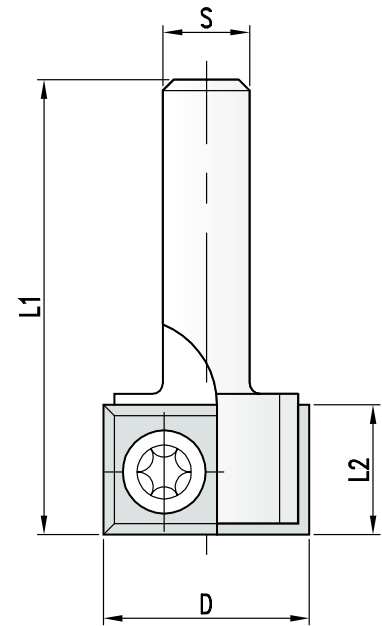

HW · MAN

L2	L1	S	Z	Ref.
12	59	6	2	3501.019.012.06
19	12	59	8	3501.019.012.08

ACESSÓRIOS - Piezas de recambio

	Dim.	Ref.
Lâmina	12x12x1,5	5003.01.1
Parafuso (torx)	M4x6	5109.006
Rolamento	19x6x6	5100.04
Chave Torx	T15	5302.202

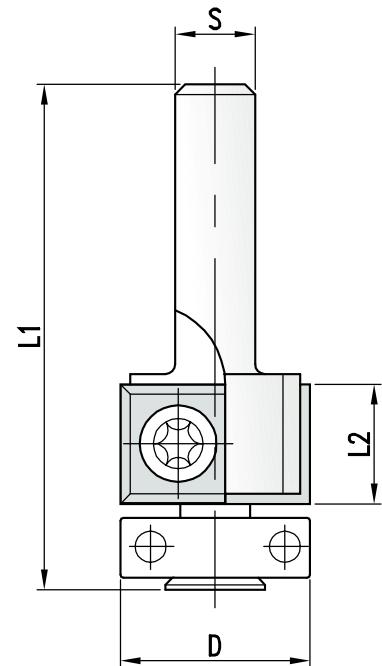



3502 Porta-lâminas para afagar Porta-cuchillas para refundir con cuchillas reversibles

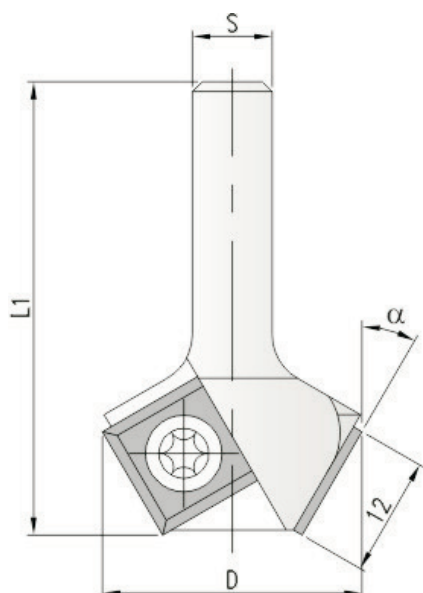

HW · MAN

D	α	L1	S	Z	Ref.
24	22°	45	6	2	3502.024.012.06
26	30°	45	6	2	3502.026.012.06
	30°	45	8	2	3502.026.012.08
29	45°	45	6	2	3502.029.012.06
	45°	45	8	2	3502.029.012.08

ACESSÓRIOS - Peças de recambio

	Dim.	Ref.
Lâmina	12x12x1,5	5003.01.1
Parafuso (Torx)	M4x6	5109.006
Chave Torx	T15	5302.202

3503 Porta-lâminas para afagar Porta-cuchillas para refundir con cuchillas reversibles

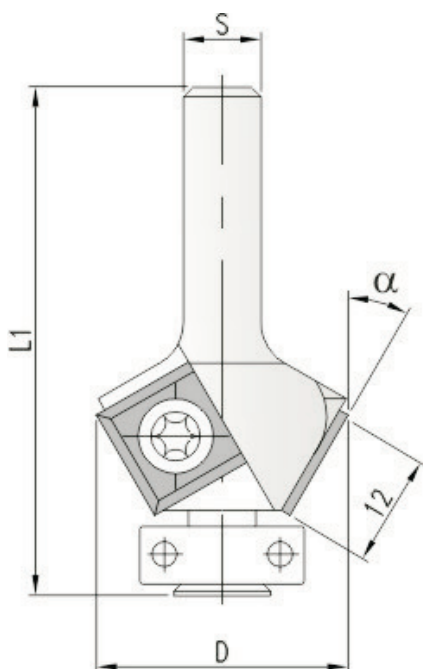

HW · MAN

D	α	L1	S	Z	Ref.
27	22	55	6	2	3503.027.012.06
	22	55	8	2	3503.027.012.08
30	30	55	6	2	3503.030.012.06
	30	55	8	2	3503.030.012.08
32	45	55	6	2	3503.032.012.06
	45	55	8	2	3503.032.012.08

ACESSÓRIOS - Peças de recambio

	Dim.	Ref.
Lâmina	12x12x1,5	5003.01.1
Parafuso (torx)	M4x6	5109.006
Rolamento	19x6x6	5100.04
Chave Torx	T15	5302.202



HW · MAN

D	L2	L1	S	Z	Ref.
18	15	45	6	2	3080.018.015.06
	15	45	8	2	3080.018.015.08

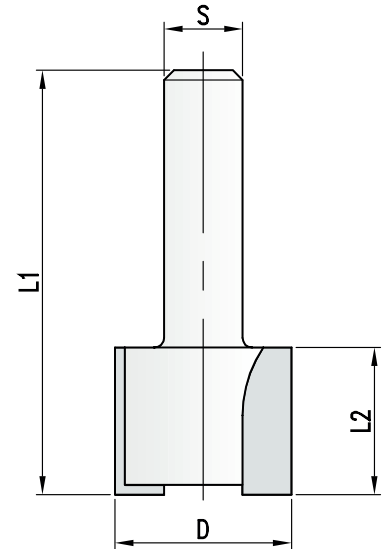

06

Fresas para máquinas portáteis · Fresas para máquinas portáteis

Fresa para afagar 3081
Fresa para refundir

HW · MAN

D	L2	L1	S	Z	Ref.
12,7	12,7	56	6	2	3081.912.912.06
	12,7	56	8	2	3081.912.912.08
12,7	25,4	67	6	2	3081.912.925.06
	25,4	67	8	2	3081.912.925.08

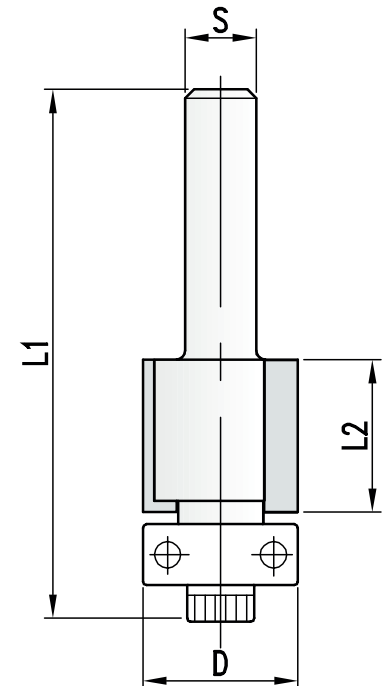

ACESSÓRIOS - Peças de recambio

	Dim.	Ref.
Rolamento	12,7x5x4,7	5100.03
Parafuso	1/8W	5112.011
Chave	3/32"	5302.001



3082 Fresa para afagar Fresa para refundir

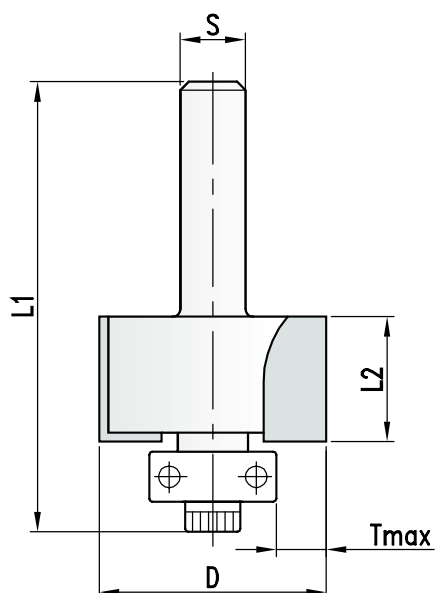

HW · MAN

D	L2	L1	S	Z	Ref.
31,8	12,7	9,5	6	2	3082.931.051.06
	12,7	9,5	8	2	3082.931.051.08

ACESSÓRIOS - Peças de recambio

	Dim.	Ref.
Rolamento	12,7x5x4,7	5100.03
Parafuso	1/8W	5112.011
Chave	3/32"	5302.001

06

Fresas para máquinas portáteis · Fresas para máquinas portáteis

3100 Fresa para ranhurar Fresa para ranurar

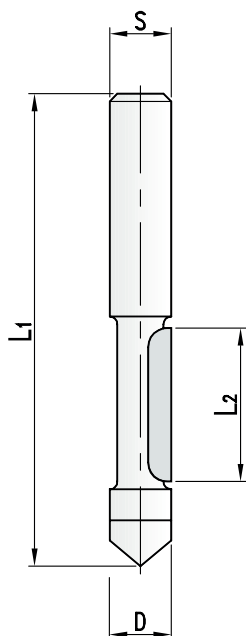

HW · MAN

D	L2	L1	S	Z	Ref.
6,35	20	62	6	1	3100.096.020.06
	20	62	8	1	3100.096.020.08
8	20	62	6	1	3100.008.020.06
	20	62	8	1	3100.008.020.08



HW · MAN

D	L2	L1	S	Z	Ref.
10	9,5	40	6	1	3101.010.909.06
	9,5	47	8	1	3101.010.909.08

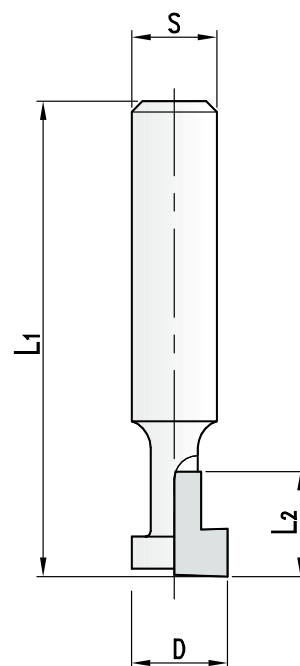

Fresa para afagar 3084
Fresa para refundir

HW · MAN

D	L2	α	L1	S	Z	Ref.
12,7	12,7	15°	51	6	2	3084.912.912.06
	12,7	15°	51	8	2	3084.912.912.08
25,4	10	30°	38,5	6	2	3084.925.010.06
	10	30°	38,5	8	2	3084.925.010.08
34,9	10	45°	38,5	6	2	3084.934.010.06
	10	45°	38,5	8	2	3084.934.010.08

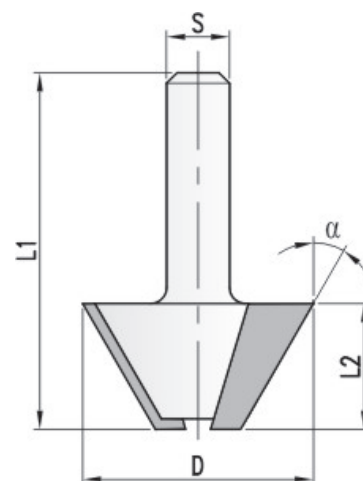



3085 Fresa para afagar Fresa para refundir

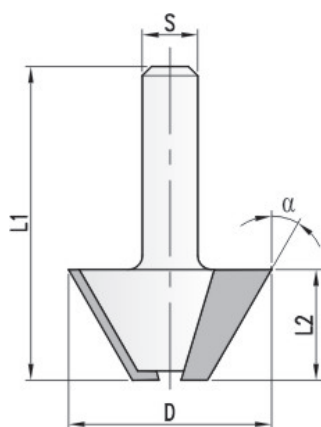

HW · MAN

D	L2	L1	α	S	Z	Ref.
19	10	49	15°	6	2	3085.019.010.06
	10	49	15°	8	2	3085.019.010.08
22,2	10	49	25°	6	2	3085.922.010.06
	10	49	25°	8	2	3085.922.010.08
30	10	49	45°	6	2	3085.030.010.06
	10	49	45°	8	2	3085.030.010.08

ACESSÓRIOS - Peças de recambio

	Dim.	Ref.
Rolamento	16x5x5	xxxxxx
Parafuso	1/8W	5112.011
Chave	3/32"	5302.001

06

Fresas para máquinas portáteis · Fresas para máquinas portáteis

3053 Fresa de perfil em V Fresa ranuras em v

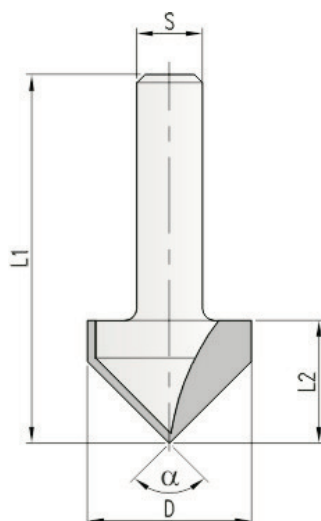

HW · MAN

D	L2	L1	α	S	Z	Ref.
12,7	16	44.5	60°	6	2	3053.912.016.06
	16	47.5	60°	8	2	3053.912.016.08
12,7	12,7	41.5	90°	6	2	3053.912.912.06
	12,7	44	90°	8	2	3053.912.912.08
19,1	16	45	90°	6	2	3053.919.016.06
	16	48	90°	8	2	3053.919.016.08
25,4	19	48	90°	6	2	3053.925.016.06
	19	51	90°	8	2	3053.925.016.08



HW · MAN

D	L2	L1	α	S	Z	Ref.
5.3	4	43	17°	6	2	3021.905.904.06
7.9	6	43	18°	6	2	3021.907.906.06
9.3	7.3	43	19°	6		3021.909.907.06
14,7	14,3	58	12°	6	2	3021.914.914.06
	14,3	58	12°	8	2	3021.914.914.08

HW · MAN

D	L2	L1	α	S	Z	Ref.
14,3	13,5	55	13°	6	2	3021.914.913.06
	13,5	55	13°	8	2	3021.914.913.08

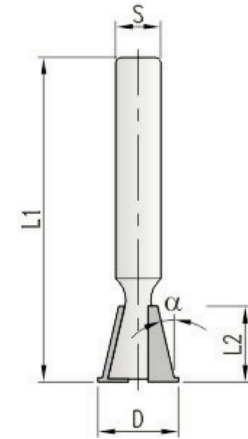
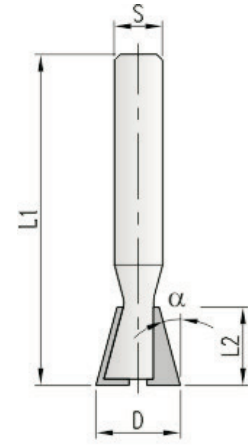

Fresa convexa para 1/4 de círculo 3004
Fresa convexa

HW · MAN

D	L2	L1	R	S	Z	Ref.
8	12	49	4	6	2	3004.008.012.06
	12	49	4	8	2	3004.008.012.08
10	12	46	5	6	2	3004.010.012.06
	12	46	5	8	2	3004.010.012.08
12	14	46	6	6	2	3004.012.014.06
	14	46	6	8	2	3004.012.014.08
14	14	46	7	6	2	3004.014.014.06
	14	46	7	8	2	3004.014.014.08
16	16	48	8	6	2	3004.016.016.06
	16	48	8	8	2	3004.016.016.08
20	16	48	10	6	2	3004.020.016.06
	16	48	10	8	2	3004.020.016.08

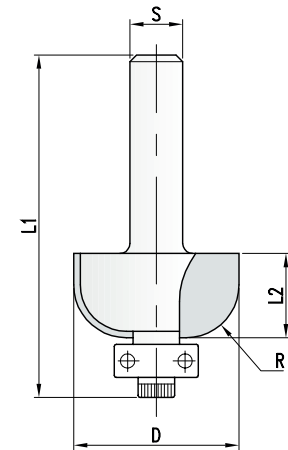



3007 Fresa cônica para 1/4 de círculo Fresa bordón

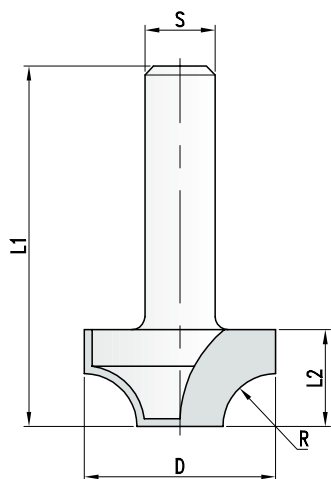

HW · MAN

D	L2	L1	R	S	Z	Ref.
9,5	8	43	3,2	6	2	3007.909.008.06
	8	43	3,2	8	2	3007.909.008.08
15	9	40,5	5	6	2	3007.015.009.06
	9	40,5	5	8	2	3007.015.009.08
20	9	40,5	4	6	2	3007.020.009.06
	9	40,5	4	8	2	3007.020.009.08
22	10	44	5	6	2	3007.022.010.06
	10	44	5	8	2	3007.022.010.08
24	11	44	6	6	2	3007.024.011.06
	11	44	6	8	2	3007.024.011.08
26	12	44	7	6	2	3007.026.012.06
	12	44	7	8	2	3007.026.012.08
28	13	46	8	6	2	3007.028.013.06
	13	46	8	8	2	3007.028.013.08
32	15	46	10	6	2	3007.032.015.06
	15	46	10	8	2	3007.032.015.08

3002 Fresa cônica para 1/4 de círculo Fresa bordón

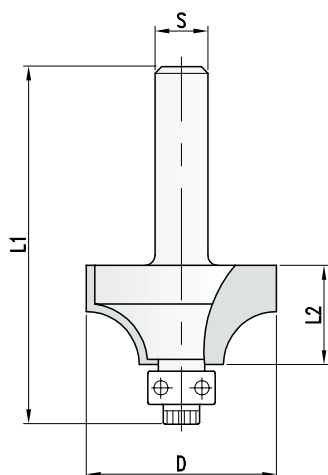

HW · MAN

D	L2	L1	R	S	Z	Ref.
15,9	8	47	1,6	6	2	3002.915.008.06
	8	50	1,6	8	2	3002.915.008.08
19,1	9,5	50	3,2	6	2	3002.919.909.06
	9,5	53	3,2	8	2	3002.919.909.08
22,2	12,7	52	4,8	6	2	3002.922.912.06
	12,7	55,5	4,8	8	2	3002.922.912.08
25,4	12,7	51,5	6,3	6	2	3002.925.912.06
	12,7	55	6,3	8	2	3002.925.912.08
28,6	13,5	53	7,9	6	2	3002.928.913.06
	13,5	56	7,9	8	2	3002.928.913.08
31,8	16	55,5	9,5	6	2	3002.931.016.06
	16	59	9,5	8	2	3002.931.016.08
38,1	19	58	12,7	6	2	3002.938.019.06
	19	61	12,7	8	2	3002.938.019.08

ACESSÓRIOS - Peças de recambio

	Dim.	Ref.
Rolamento	9,5x3,1x4,7	5100.02
Parafuso	1/8W	5112.011
Chave	3/32"	5302.001



HW · MAN

D	L2	L1	R	S	Z	Ref.
15,9	8	47	1,6	6	2	3003.915.008.06
	8	50	1,6	8	2	3003.915.008.08
19,1	9,5	50	3,2	6	2	3003.919.909.06
	9,5	53	3,2	8	2	3003.919.909.08
22,2	12,7	52	4,8	6	2	3003.922.912.06
	12,7	55,5	4,8	8	2	3003.922.912.08
25,4	12,7	51,5	6,3	6	2	3003.925.912.06
	12,7	55	6,3	8	2	3003.925.912.08
28,6	13,5	53	7,9	6	2	3003.928.913.06
	13,5	56	7,9	8	2	3003.928.913.08
31,8	16	55,5	9,5	6	2	3003.931.916.06
	16	59	9,5	8	2	3003.931.916.08
38,1	19	58	12,7	6	2	3003.938.919.06
	19	61	12,7	8	2	3003.938.919.08

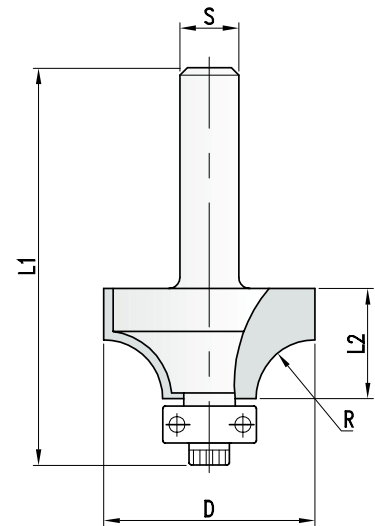

ACESSÓRIOS - Piezas de recambio

	Dim.	Ref.
Rolamento	9,5x3.1x4,7	5100.03
Parafuso	1/8W	5112.011
Chave	3/32"	5302.001

Fresa cônica para 1/2 de círculo **3006**
Fresa semi-circular

HW · MAN

D	L2	L1	R	S	Z	Ref.
19,8	19	51	5	6	2	3006.919.019.06
	19	51	5	8	2	3006.919.019.08
23	25	58	7	6	2	3006.023.025.06
	25	58	7	8	2	3006.023.025.08

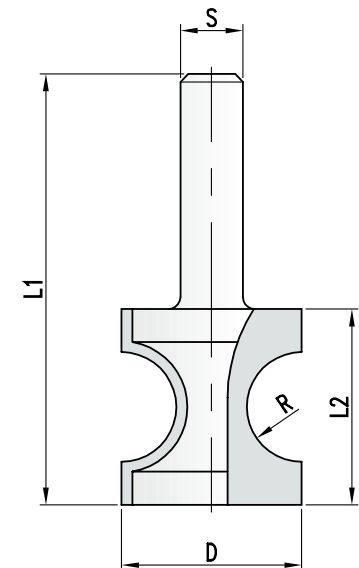
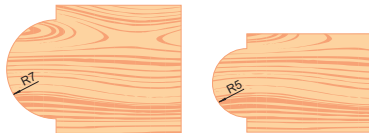



3040 Fresa de perfil Fresa perfilada

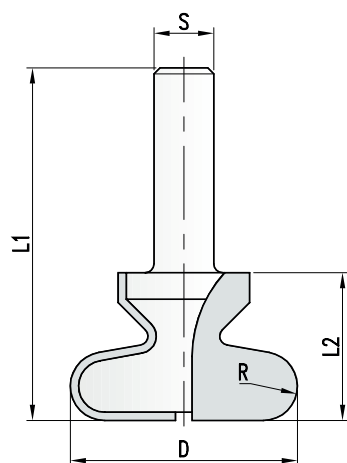

HW · MAN

D	L2	L1	R	S	Z	Ref.
19,1	19	57	4,8	10	2	3040.919.019.10
	19	57	4,8	12	2	3040.919.019.12
38,1	21	59	6	10	2	3040.938.021.10
	21	59	6	12	2	3040.938.021.12

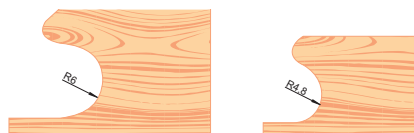

3041 Fresa de perfil Fresa perfilada

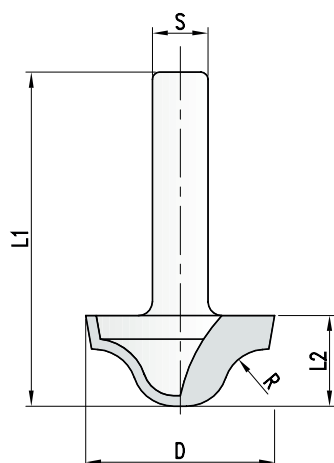

HW · MAN

D	L2	L1	R	S	Z	Ref.
21	10	42	4	6	2	3041.021.010.06
	10	42	4	8	2	3041.021.010.08
27	13	45	6	6	2	3041.027.013.06
	13	45	6	8	2	3041.027.013.08

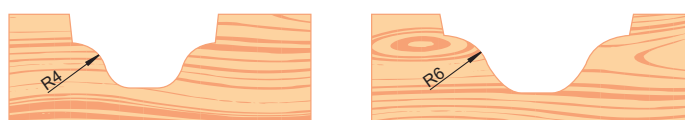

3042 Fresa de perfil Fresa perfilada

HW · MAN

D	L2	L1	R	S	Z	Ref.
27	11,9	52	6	6	2	3042.027.911.06
	11,9	52	6	8	2	3042.027.911.08

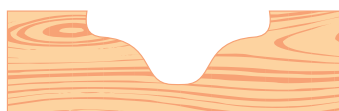



HW · MAN

D	L2	L1	R1/R2	S	Z	Ref.
112,7	10,5	51	2,3/3,5	6	2	3043.912.910.06
	10,5	51	2,5/3,5	8	2	3043.912.910.08
19,1	12,7	54	3,7/4,0	6	2	3043.919.912.06
	12,7	54	3,7/4,0	8	2	3043.919.912.08
25,4	17,5	73	5,0/6,3	6	2	3043.925.917.06
	17,5	73	5,0/6,3	8	2	3043.925.917.08

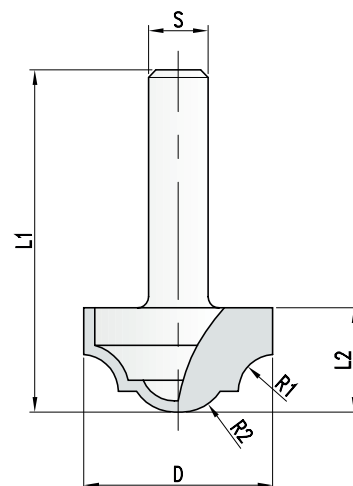
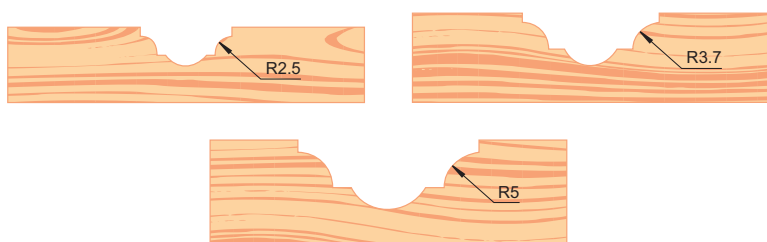

Fresa de perfil
Fresa perfilada

3045

HW · MAN

D	L2	L1	R	S	Z	Ref.
21	14	46	4,5	6	2	3045.021.014.06
	14	46	4,5	8	2	3045.021.014.08

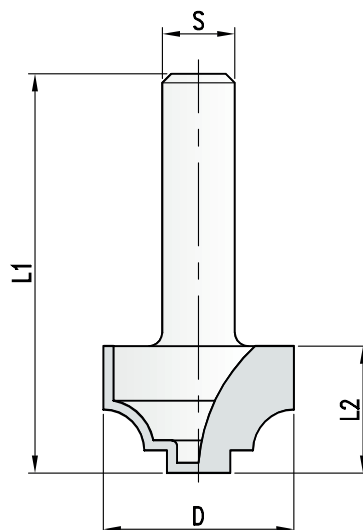

Fresa de perfil
Fresa perfilada

3046

HW · MAN

D	L2	L1	R	S	Z	Ref.
33	15	47	4	8	2	3046.033.015.08

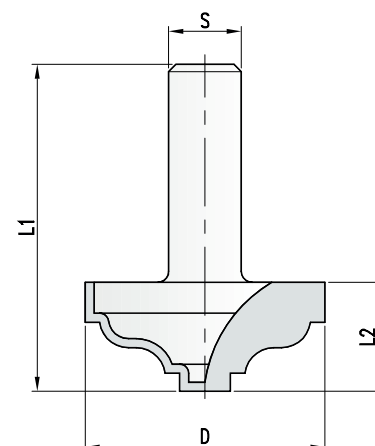
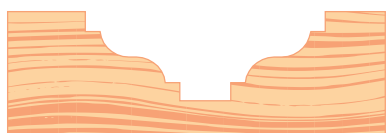



3044 Fresa de perfil Fresa perfilada

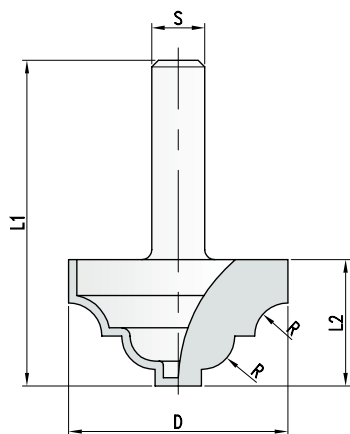

HW · MAN

D	L2	L1	R/R	S	Z	Ref.
27	13	45	4/4	8	2	3044.027.013.08
33	17	49	5/5	8	2	3044.033.017.08

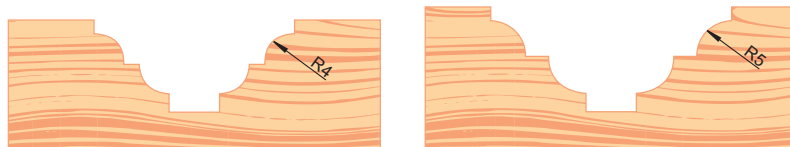

3050 Fresa de perfil Fresa perfilada

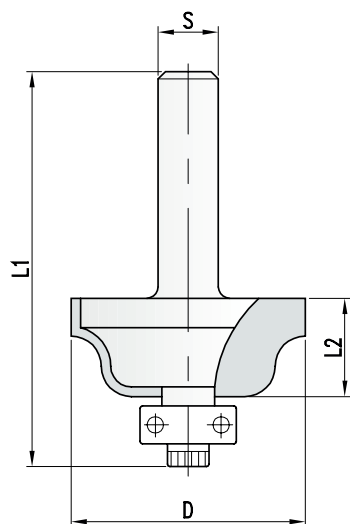

HW · MAN

D	L2	L1	R	S	Z	Ref.
25,4	15,9	54	4	6	2	3050.925.915.06
	15,9	54	4	8	2	3050.925.915.08
34,9	20	57	6,3	6	2	3050.934.920.06
	20	57	6,3	8	2	3050.934.920.08

ACESSÓRIOS - Peças de recambio

	Dim.	Ref.
Rolamento	9,5x3,9x3,1	5100.01
Parafuso	3/32W	5112.012
Chave	5/64"	5302.002

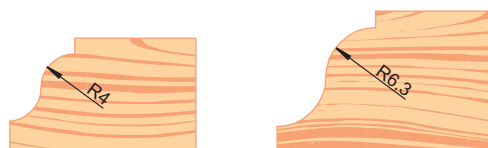

3047 Fresa de perfil Fresa perfilada

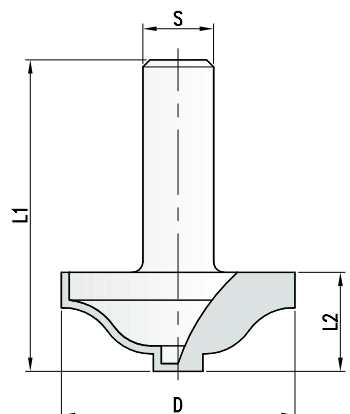

HW · MAN

D	L2	L1	R	S	Z	Ref.
33	14	49	7,5	8	2	3047.033.014.08

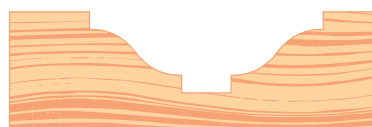



HW · MAN

D	L2	L1	R	S	Z	Ref.
25,4	16	57	4	6	2	3048.925.016.06
	16	57	4	8	2	3048.925.016.08
34,9	20	60	6,3	6	2	3048.934.020.06
	20	60	6,3	8	2	3048.934.020.08

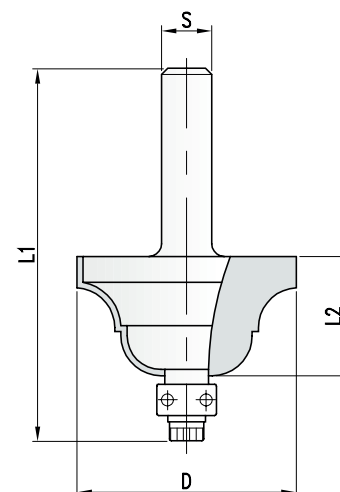

ACESSÓRIOS - Piezas de recambio

	Dim.	Ref.
Rolamento	9,5x3,9x3,1	5100.051
Parafuso	3/32W	5112.012
Chave	5/64"	5302.002

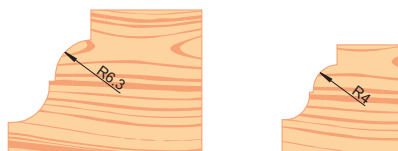

Fresa de perfil 3051
Fresa perfilada

HW · MAN

D	L2	L1	R	S	Z	Ref.
34,9	13,5	53	4	6	2	3051.934.913.06
	13,5	53	4	8	2	3051.934.913.08
41,3	19,1	68	6,3	6	2	3051.941.919.06
	19,1	68	6,3	8	2	3051.941.919.08

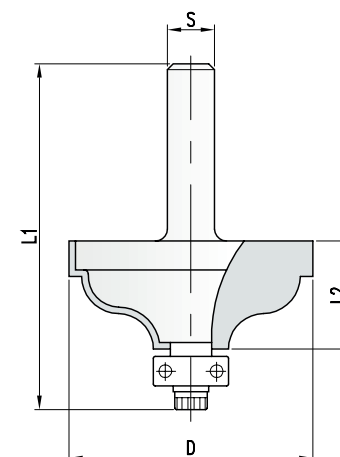

ACESSÓRIOS - Piezas de recambio

	Dim.	Ref.
Rolamento	12,7x5x4,7	5100.03
Parafuso	1/8W	5112.011
Chave	3/32"	706.161

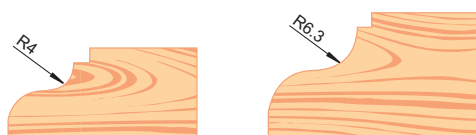



3052 Fresa de perfil Fresa perfilada

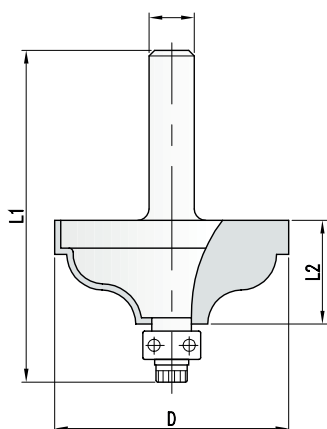

HW · MAN

D	L2	L1	R	S	Z	Ref.
34,9	13,5	53	4	6	2	3052.934.913.06
	13,5	53	4	8	2	3052.934.913.08
41,3	19,1	68	6,3	6	2	3052.941.919.06
	19,1	68	6,3	8	2	3052.941.919.08

ACESSÓRIOS - Peças de recambio

	Dim.	Ref.
Rolamento	9,5x3,1x4,7	5100.02
Parafuso	1/8W	5112.011
Chave	3/32"	5302.001

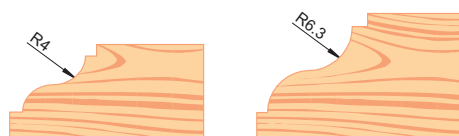

3065 Fresa de ranhurar Fresa ranurar

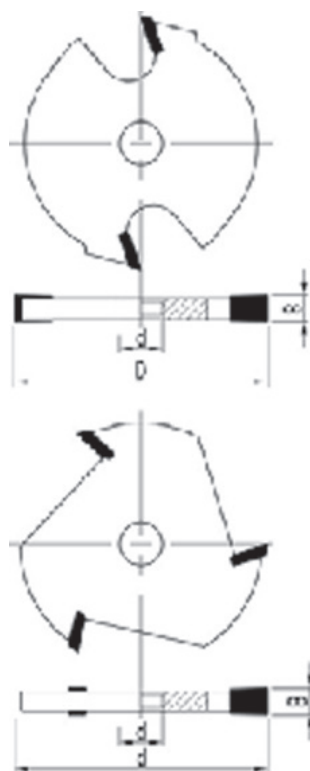

HW · MAN

D	B	d	Z	Ref.
40	1,5	8	2	3065.040.901.08
	2	8	2	3065.040.002.08
	2,5	8	2	3065.040.902.08
	3	8	2	3065.040.003.08
4	8	2	3065.040.004.08	

HW · MAN

D	B	d	Z	Ref.
47,6	1,5	8	3	3065.947.901.08
	2	8	3	3065.947.002.08
	2,5	8	3	3065.947.902.08
	3	8	3	3065.947.003.08
	3,5	8	3	3065.947.903.08
	4	8	3	3065.947.004.08
	5	8	3	3065.947.005.08
	6	8	3	3065.947.006.08



HW · MAN

d1	L2	L1	S	Ref.
Tipo 1				
8	25	63	6	3120.008.025.06
	25	63	8	3120.008.025.08
8	38	76	6	3120.008.038.06
	38	73	8	3120.008.038.08
Tipo 2				
8	25	63	6	3120.008.325.06
	25	63	8	3120.008.325.08
8	38	76	6	3120.008.338.06
	38	73	8	3120.008.338.08

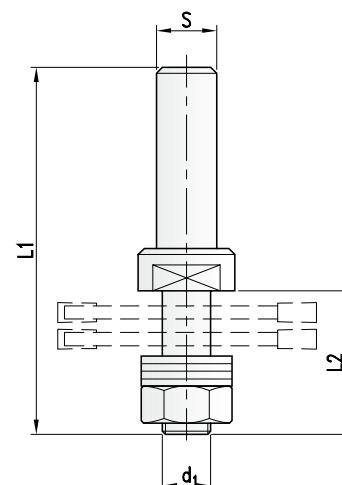

ACESSÓRIOS - Piezas de recambio

	Dim.	Ref.
Rolamento	19x6x6	5100.05
Parafuso	M8	
Anilha		
	16x0,1x8	
	16x0,4x8	
	16x0,5x8	
	16x1x8	
	16x3x8	
	16x6x8	

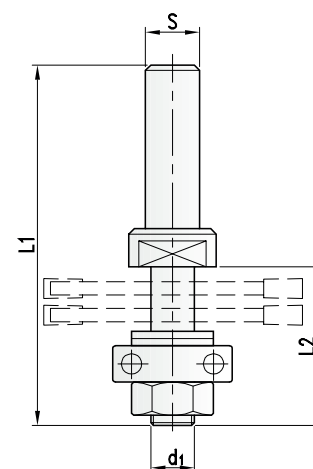

araújo&silva
ferramentas de corte

www.araujosilva.pt